

# A new parameter and its effect on the formability in single point incremental forming: A fundamental investigation<sup>†</sup>

Ghulam Hussain\*, Gao Lin and Nasir Hayat

College of Mechanical & Electrical Engineering, Nanjing University of Aeronautics & Astronautics, Nanjing, 210016, P.R. China

(Manuscript Received July 14, 2009; Revised March 30, 2010; Accepted April 10, 2010)

## Abstract

A new parameter, blank stiffness, with a potential effect on the formability in single point incremental forming (SPIF) has been introduced and investigated. Various plates with a square hole at the center and half-side length of the square ranging from 12-56mm were used as backing plates for blanks. It is shown that with a decrease in the size of hole/work-piece, there is an increase in the blank stiffness. This increase in the stiffness in turn adversely affects the formability in SPIF process.

**Keywords:** Blank stiffness; Formability; Incremental forming

## 1. Introduction

Single point incremental forming (SPIF) is a novel sheet forming process. In this process, three-dimensional shaping is performed without the use of dedicated dies. A sheet blank supported on a hollow backing plate is held at its periphery with a clamping plate (see Fig. 1). A steel rod with the hemispherical end traverses a pre-defined tool path, generated in CAD/CAM software, to deform the sheet in a series of incremental steps. Wall/sheet thinning in SPIF mainly depends on the deformation/wall angle imposed on the sheet blank and can be predicted by the sine law (*i.e.*  $t = t_0 \sin \theta$ ) [1, 2], where  $t$  is the wall thickness,  $t_0$  is the blank thickness and  $\theta$  is the deformation/wall angle (see definition in Fig. 1). The formability in SPIF is defined as the maximum wall angle ( $\theta_{\max}$ ) that a sheet would endure without fracturing [1]. Several parameters related to part geometry (shape, curvature etc.), process (feed rate, tool size etc.) and material (thickness, properties etc.) can affect the sheet formability. A decrease in the curvature (in a plane perpendicular to the tool axis) of the tool path causes a decrease in the formability [3]. Large tool size and feed rate adversely affect the formability [4, 5]. Thick sheet formed with an optimal size of tool enhances the formability [5]. True thickness strain at tensile fracture is the major influential material property for the formability: a sheet possessing higher value of this property exhibits higher formability [6].

Strength, stiffness and spring back are all important sheet metal properties. These properties are strongly interrelated. In structural analysis, stiffness is the resistance of a body to deformation [7]. For thin deep drawn thin panels, stiffness is defined as the amount of resistance to elastic deformation [8]. An increase in stiffness has a positive effect on the dent resistance of thin panels [9]. The stiffness decreases with increasing the size and curvature of the panel and increases with increasing the panel thickness [10-13].

In SPIF, the tool exerts a point load normal to the blank clamped on a hollow backing plate. *Sheet blank stiffness* in SPIF, therefore, can be defined as the resistance to a point load exerted normally to the blank. Therefore, considering the sheet blank as a diaphragm, the stiffness will vary from point to point, being least at the center and maximum near the restrained (*i.e.*, clamped) boundary. Moreover, stiffness will vary with a variation in the size of the clamped blank (*i.e.*,  $L$  as defined in Fig. 2(a)). These variations, depending on the location and blank size, will cause the sheet to undergo differ-

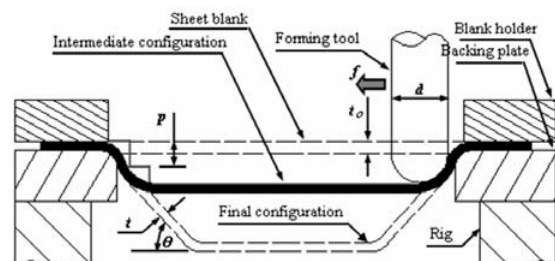

Fig. 1. Schematic of SPIF process.

<sup>†</sup>This paper was recommended for publication in revised form by Associate Editor Dae-Eun Kim

\*Corresponding author. Tel.: +86 1367 5161625, Fax.: +86 25 84896469

E-mail address: gh\_ghumman@yahoo.com

© KSME & Springer 2010

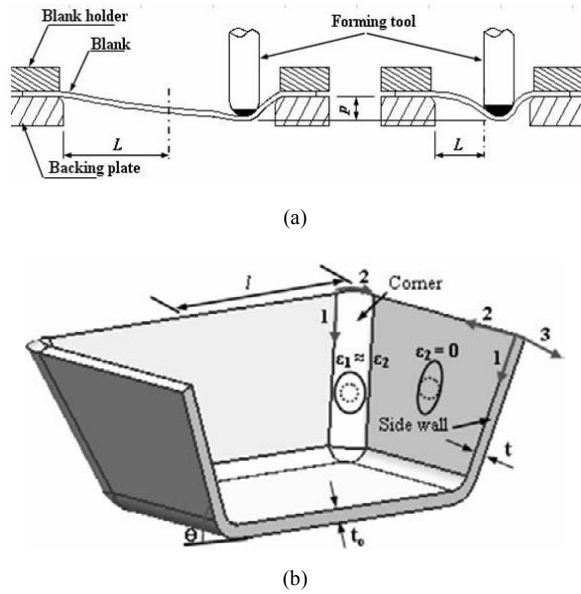

Fig. 2. (a) Elastic deformation in sheet blank at varying hole size of backing plate, and (b) Pyramidal geometry used for SPIF tests.

ent amount of elastic deformations (deflection) at different locations. The elastic deformation will affect tool/sheet contact, as demonstrated in Fig. 2(a), in such a way that a shorter blank will endure higher longitudinal strain. This will lead to sheet fracture at a smaller wall angle and hence will reduce the forming limit of the sheet. The amount of elastic deformation induced in a sheet under point load is linked with the sheet stiffness. The effect of sheet blank stiffness, if any, on the formability in SPIF has not been explored so far. The current study is an attempt in this direction. The blank thickness, elastic modulus and boundary conditions could also affect the sheet stiffness; however, this study is focused only on the influence of sheet blank size (i.e.,  $L$ ) with other parameters held constant.

In the current investigations, initially an FE analysis was performed to examine the influence of variation in the blank stiffness on wall thinning. Later, systematic experimental investigations were conducted to quantify this effect. To do so, a set of backing plates with square holes at their center and the half-side length of the hole (i.e.,  $L$  as defined in Fig. 2(a) varying over a wide range (12-56mm) were used to obtain different levels of blank stiffness. And, a pyramid with a square base was employed as the geometry of the formability test. The reason behind choosing the pyramidal geometry was to avoid the adverse effect of hoop strains on fracture, while reducing geometry size (hoop strains increase with the decreasing of part curvature [3]), so that the sole effect of stiffness could be quantified. The half-side length of the pyramid (i.e.,  $l$  as defined in Fig. 2(b) was governed by the relation:  $l = L - 2t_0$ , where  $t_0$  is the blank thickness. It should be noted that  $L$  is the workable size of blank excluding the restrained periphery.



Fig. 3. Effect of blank stiffness on wall thinning examined in LS-DYNA.

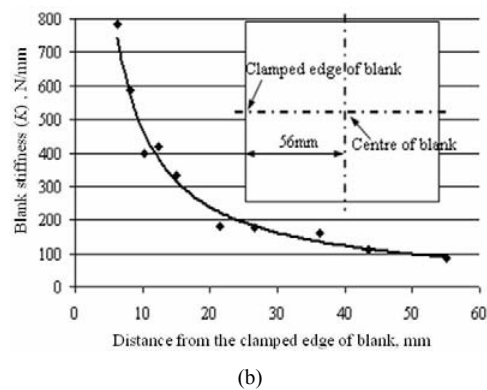
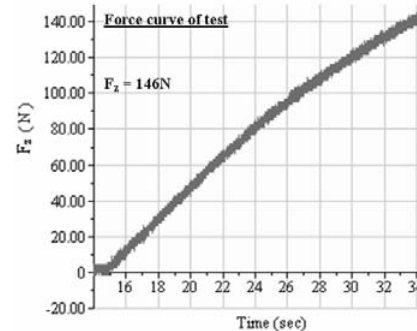
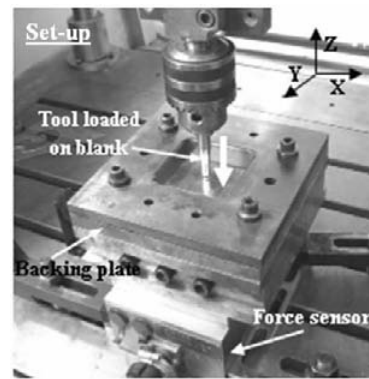

Fig. 4. (a) Stiffness test, and (b) Stiffness distribution over a blank clamped on a backing plate.

## 2. Verification of concept through finite element analysis

Though the above discussion shows that a smaller blank may undergo higher wall thinning, FE analysis, prior to performing detailed experimental investigations, was conducted so as to validate this point. To determine the trend in wall thinning with variation in the blank size, only two representative sheet blanks were deformed into square pyramids. The upper limit on the blank size (i.e.,  $L=56\text{mm}$ ) was set, keeping in view the X-Y travel of machine tool. And, the lower limit (i.e.,  $L=12\text{mm}$ ) was set, keeping in view the availability of clamping plates. The process modeling was carried out using a commercial FE software LS-DYNA. The deformation angle,  $\theta$ , was set at  $59^\circ$  for both the cases. The sheet was discretized into square shell elements with  $(0.6 \times 0.6)\text{mm}$  size. The coefficient of friction, which was experimentally determined by employing pin on a disc apparatus, was fixed at 0.12. For the punch, a rigid material behavior was defined. In the simulations, the run time of calculation was notably decreased using the mass scaling and a high feed rate [13].

Fig. 3 shows the distribution of wall thinning (in %) on the pyramids. As expected, the pyramid with  $L=12\text{mm}$  underwent higher thinning than the one with  $L=56\text{mm}$ , which can be attributed to variation in the blank stiffness. This means that the sheet in the small pyramid will reach its limiting strain at a smaller wall angle as compared to that in the large pyramid, hence showing a lower value of maximum endurable angle (i.e., formability). This indicates that a variation in the blank size (or blank stiffness) could affect the formability. This point was further investigated through a series of experiments, reported in the coming sections.

## 3. Stiffness tests

A similar procedure, as adopted by Ekstrand and Asnafi [9] to determine panel stiffness, was employed to evaluate the blank stiffness in SPIF. During testing, the same boundary conditions as to be used during SPIF were imposed (see Fig. 4(a)). The stiffness was measured by pressing a hemispherical headed forming tool (diameter = 8 mm) in vertical direction in the tightly held sheet blank (1.4mm thick and made of AA-2024O aluminum) at the desired point, and then by continuously recording the force using a force dynamometer (Fig. 4(a)). With the help of recorded force, the blank stiffness at the desired point was found from the equation,  $F = Kz$ , where  $F$  is the maximum force,  $K$  is the blank stiffness and  $z$  is the vertical displacement (0.3mm). During the preliminary experiments with various blanks held tightly on the backing plates with different hole size  $L$ , the blank stiffness was measured at various equally spaced points from the center towards the clamped edge. It was found that the stiffness was the maximum at the clamped edge and the minimum at the center, as shown in an example in Fig. 4(b). From the curve shown in Fig. 4(b), the equivalent stiffness (i.e.,  $K_{eq}$ ) for each blank was defined by taking the average of at least four points (number

Table 1. Experimental plan.

L [mm]	L [mm]	Remarks
12	9	The forming depth was kept constant at 13mm
14	11	
16.5	13.5	
20.5	17.5	
25.5	22.5	
35	32	
56	53	

of points varied from 4 to 8 depending on the size of the blank).

## 4. Incremental forming tests

The same material and thickness as used in stiffness tests were employed. For all kinds of SPIF tests, the following constant parameters were employed: feed rate ( $f$ ) = 1.2 m/min, incremental step size ( $p$ ) = 0.3 mm, and tool diameter ( $d$ ) = 8 mm (see definitions in Fig. 1). The mineral oil was used as a lubricant.

### 4.1 Effect of blank stiffness on wall thinning

To study the effect of equivalent blank stiffness,  $K_{eq}$ , on wall thinning, pyramids using square hole backing plates were formed by varying the size  $L$  of hole/blank as shown in Table 1, while the wall angle,  $\theta$ , was kept constant at  $59^\circ$ . For each value of  $L$ , two pyramids were formed so as to provide statistical means. The sole influence of change in blank stiffness on wall thinning can easily be determined just by knowing the wall thickness at varying  $K_{eq}$ . To do so, points were marked on the side wall, as defined in Fig. 2(b), of each formed pyramid along the depth. The sheet thickness on each marked point was measured using a point micrometer with  $\pm 0.001\text{mm}$  accuracy.

### 4.2 Effect of blank stiffness on formability

To test the sheet formability, the sheet was formed with a variety of wall angles. The wall angle was increased in small steps until the sheet endured the maximum angle without fracturing ( $\theta_{max}$ ). This procedure was repeated for each size  $L$  of backing plate given in Table 1. In this way, a set of  $\theta_{max}$  at varying  $K_{eq}$  was determined.

## 5. Experimental results and discussion

### 5.1 Correlation of equivalent blank stiffness with the size of backing plate/blank

It can be seen from Fig. 5 that with an increase in the hole size ( $L$ ) of the backing plate, there is a decrease in the equivalent blank stiffness ( $K_{eq}$ ). The rate of decrease in  $K_{eq}$  is higher

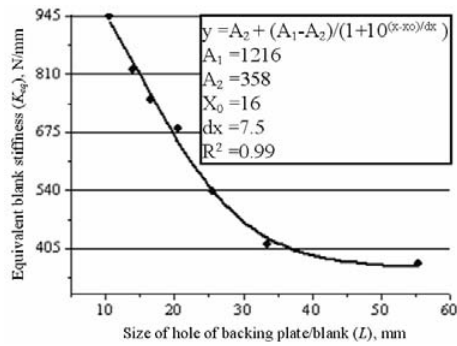

Fig. 5. Correlation of hole size of backing plate/blank with the equivalent blank stiffness.

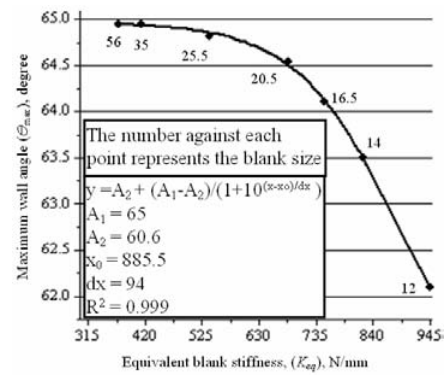

Fig. 7. Effect of blank stiffness on the formability.

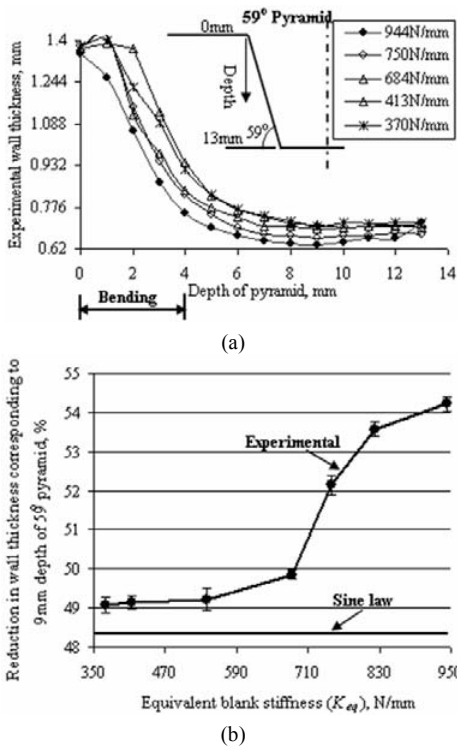

Fig. 6. Wall thickness profiles of pyramids at selected values equivalent blank stiffness, and (b) Experimental wall thinning at selected pyramid depth as function of equivalent blank stiffness.

for  $L$  ranging from 12–35mm and drops significantly afterwards. A higher value of  $K_{eq}$  means that the blank is stiffer and will demonstrate relatively lesser elastic deformation and higher wall thinning as compared to the blank having smaller value of  $K_{eq}$ .

**5.2 Effect of blank stiffness on wall thinning**

Fig. 6(a) shows the experimental wall thickness at different points along the depth of pyramids for various  $K_{eq}$ . It is clear from this figure that with an increase in  $K_{eq}$  (which in turn depends on the size  $L$  of hole/blank), the experimentally measured thickness decreases. This means that an increase in  $K_{eq}$  causes an increase in wall thinning and thus endorses the

FEA finding reported earlier. Fig. 6(b), which presents percent reduction in thickness (i.e., wall thinning) corresponding to 9mm depth of pyramids as a function of  $K_{eq}$ , further reinforces this finding. This figure shows that the experimental wall thinning increases with an increase in  $K_{eq}$ . However, the wall thinning predicted by the sine law, which is commonly used in SPIF to predict wall thinning [1], remains constant throughout the investigated range of  $K_{eq}$ . This increase in experimental wall thinning (i.e., 11% approximately) can be attributed to an increase in  $K_{eq}$ . Furthermore, it can be said that the sine law is unable to precisely predict wall thinning while taking into account the effect of blank stiffness.

It is to be noticed from Fig. 6(a) that each wall thickness profile contains a thinnest point. Such a thinnest point on the wall thickness profile was also reported in [2]; however, the reason for its formation was not reported. The blank stiffness corresponding to this thinnest point is very high (see Fig. 4 (b)) and this seems the major reason for excessive thinning of blank at this particular location. However, further investigations are needed to clarify this point. It should be noted that  $k$  is the blank stiffness on a selected point of blank and  $K_{eq}$  is the equivalent blank stiffness of various points on blank including center and outer edge of the blank.

**5.3 Blank stiffness and formability**

It can be observed from Fig. 7 that the value of  $\theta_{max}$  (i.e., formability) decreases as the  $K_{eq}$  increases. However, the rate of decrease in  $\theta_{max}$  with an increase in  $K_{eq}$  is not the same throughout the investigated range. After 525 N/mm, with an increase in  $K_{eq}$ ,  $\theta_{max}$  reduces sharply. The blank size  $L$  against each point has also been shown in Fig. 7. It is worth noticing that an increase in the blank size after 35mm does not considerably affect the formability. The total decrease in  $\theta_{max}$ , in the investigated range of  $K_{eq}$ , is about 5%. The decrease in  $\theta_{max}$  with increase in  $K_{eq}$  can be attributed to increase in wall thinning, as shown in Fig. 6 (b).

An empirical model describing the effect of variation in  $K_{eq}$  on  $\theta_{max}$  can be established as:

$$\theta_{max} = A_2 + (A_1 - A_2) / (1 + 10^{(K_{eq} - x_0) / dx}) \tag{1}$$

where  $A_1 = 65$ ,  $A_2 = 60.6$ ,  $x_0 = 885.5$  and  $dx = 94$ .

The above equation reveals that for  $370 < K_{eq} < 945$ , the formability is governed by a Boltzmann model. The  $R^2$  (multiple correlation factor) value for the equation is more than 99%, which confirms that the data points are well fitted to the curves of the respective models.

## 6. Conclusions

A new parameter, blank stiffness, in the SPIF process was introduced and a fundamental investigation regarding its influence on the formability was performed. The important findings of the study are summarized as follows:

The equivalent blank stiffness (i.e.  $K_{eq}$ ) decreases as the size of hole of backing plate/blank (i.e.  $L$ ), increases. For small values of  $L$  (up to 35mm), the value of  $K_{eq}$  sharply decreases with an increase in  $L$ . However, for large values of  $L$  (for 35mm and above) the decrease in  $K_{eq}$  with increase in  $L$  is minimal.

For  $K_{eq} \geq 420$ N/mm, wall thinning increases with increasing of  $K_{eq}$ .

The formability (i.e.,  $\theta_{max}$ ) decreases as  $K_{eq}$  increases. However, this effect can be seen for  $K_{eq}$  ranging from 420-945N/mm. The formability of blanks with  $K_{eq} < 420$ N/mm remains unaffected.

The total decrease in the formability in the investigated range of  $K_{eq}$  was found to be about 5%.

## Nomenclature

$L$	: Half-side length of square hole of backing plate
$l$	: Half-side length of square base of pyramid
$\theta$	: Wall angle
$\theta_{max}$	: Maximum wall angle without sheet fracture
$K$	: Blank stiffness measured at one point
$K_{eq}$	: Equivalent blank stiffness of whole blank

## References

- [1] J. Jeswiet, F. Micari, G. Hirt, A. Bramley, J. Duflou and J. Allwood, Asymmetric single point incremental forming of sheet metal, *CIRP Annal.*, 54 (2005) 623-650.  
D. Young and J. Jeswiet, Wall thickness variations in single point incremental forming, *Proc. of IMechE, Part B: J. Engrg. Manuf.*, 218 (2004) 1453-1459.
- [2] M. S. Shim and J. J. Park, The formability of aluminum sheet in incremental forming, *J. Mater. Process. Technol.*,

113 (2001) 654-658.

- [3] Y. H. Kim and J. J. Park, Effect of process parameters on the formability in incremental forming of sheet metal, *J. Mater. Process. Technol.*, 130-131 (2002) 42-46.
- [4] G. Hussain, L. Gao and N. Hayat, The formability of annealed and pre-aged AA-2024 sheets in single point incremental forming, *Int. J. Adv. Manuf. Technol.*, DOI: 10.1007/s00170-009-2120-x.
- [5] G. Hussain, L. Gao and N. Hayat, A new formability indicator in single point incremental forming, *J. Mater. Process. Technol.*, 209 (2009) 4237-4242.
- [6] L. L. Zhao, Z. Z. Sun and Y. Y. Yang, Experimental research on the stiffness of cylindrical shallow shell, *J. Mater. Process. Technol.*, (2007) 132-135.
- [7] N. Palmquist, Stiffness and dent properties of pressed panels in aluminum for low weight vehicle programme. *Met. Lab., AB Volvo Technical Development*, (1995) 500704.
- [8] G. Ekstrand and N. Asnafi, On testing of stiffness and the dent resistance of autobody panles, *Material & Design.*, 19 (1998) 145-156.
- [9] J. A. Di-cello and R. A. George, Design criteria for the dent resistance of auto body panels, *Proc. of the Automotive Engineering Congress*, Detroit, Mich (1974) 740081.
- [10] D.-W. Jung, A parametric study of sheet metal denting using a simplified design approach, *J. Mech. Sci. Technol.*, 16 (2002) 1673-1686.
- [11] D.-W. Jung and M. J. Worswick, A parameter study for static and dynamic denting, *J. Mech. Sci. Technol.*, 18 (2004) 2009-2020.
- [12] K. B. Nielsen, M. R. Jensen and J. Danckert, Optimization of sheet metal forming processes by a systematic application of finite element simulations, *Proc. of Second European LS-DYNA user Conference*, Gothenburg, Sweden (1999) A3-A16.



**Ghulam Hussain** completed his undergraduate studies in Mechanical Engineering from UET Lahore, Pakistan in August 2000. Later, after four years working in a manufacturing industry, joined Nanjing University of Aeronautics & Astronautics, China, in order to continue his engineering studies. The author completed his Ph. D in Manufacturing Engineering in March 2009. Presently, the author is working on metal forming processes.